



# General Electronic Devices

Makers of active and passive components  
 Quartz Crystal \* Oscillators \* Synthesizer \* Filters  
 Micro-Hybrid Assembly Services

## SMD914CB(E/D)MT-25.000MHz

THIS DEVICE IS RoHS COMPLIANT

ELECTRICAL SPECIFICATIONS	
Type	9x14 mm "J lead" SMD Oscillator
Frequency	25.000MHz
Frequency Tolerance	$\pm 10\text{ppm}@25^{\circ}\text{C}$
Frequency Stability	$\pm 50\text{ppm}$ All Inclusive
Operating Temperature	-55 to +125degC
Storage Temperature	-55 - +125 °C
Input Voltage	5.0V $\pm 10\%$ VDC
Input Current	15 mA (Max)
CMOS OUTPUT: "0" Level "1" Level	10%VDD (MAX) 90% VDD (MIN)
Symmetry	40% to 60% (at 50% VDD)
Rise and Fall Time	200 nS (MAX)
Tri-State Output (EN/MC)	EN
Output Load	15pF
Start-Up Time	5 ms (typical)
Aging Rate	+ 3ppm/Year MAX

### DRAWING OUTLINE

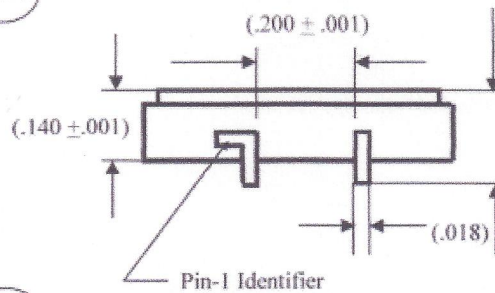
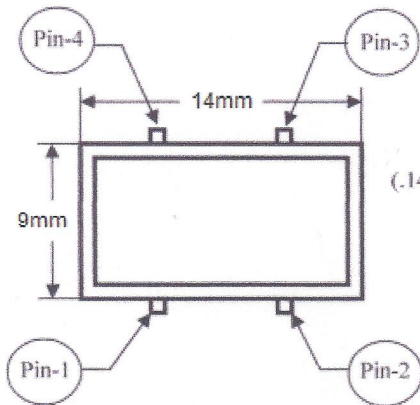

( Unit: inches )

PIN CONFIGURATION	
Pin 1	E/D
Pin 2	GND
Pin 3	OUTPUT
Pin 4	VDD